

Schäffer Lader

**COMPACT WHEEL LOADER
PIVOT STEER TELELOADER**



Power, ergonomics and flexibility

COMPACT WHEEL LOADERS AND TELELOADERS ...

from 14 kW (20 HP) to 154 kW (210 HP). At SCHÄFFER Loaders, we have a proud 50 year history of creating loaders for individual requirements. Our customers have made us what we are today: one of the world's most competitive and successful suppliers of compact wheel loaders and teleloaders. Every day our team creates new custom solutions that combine years of experience with a spirit of innovation. Our products set industry standards for reliability and durability, which means you save with lower servicing costs over the life of your vehicle. The Schäffer name is your assurance of superior performance, safety and comfort for years to come.

SCHÄFFER LOADERS



2028 | 19 kW (26 HP)
 2030 | 22 kW (30 HP)
 2033 | 24 kW (33 HP)

2336 | 26 kW (36 HP)
 2345 | 33 kW (45 HP)
 2436 | 26 kW (36 HP)
 2445 | 33 kW (45 HP)

3350 | 37 kW (50 HP)
 3360 | 44 kW (60HP)
 3450 | 37 kW (50 HP)
 3460 | 44 kW (60HP)

4350 Z | 37 kW (50 HP)
 4360 Z | 44 kW (60 HP)
 5058 Z | 44 kW (60HP)
 5058 ZS | 51 kW (70 HP)

SCHÄFFER LOADERS: POWER, ERGONOMICS AND FLEXIBILITY

Whatever you want to move, you need the right machine for the job. Working effectively often means getting a little creative to achieve peak productivity. Schäffer loaders are made to work in an easy yet cost-efficient way – with a flexibility that only Schäffer offers. You can choose from a wide product range of more than 30 models between 1,7 t and 14 t. You can be sure that your Schäffer loader will be one of the most versatile machines at site. When it comes to working tools, things really get exciting. Whatever you need technically, we can put together a customised vehicle for you.

made by SCHÄFFER



5370 Z | 51 kW (70 HP)
5390 Z | 63 kW (86 HP)
9300 Z | 81 kW (110 HP)
9330 Z | 96 kW (130 HP)

460 T | 44 kW (60 HP)
470 T | 51 kW (70 HP)

6370 T | 51 kW (70 HP)
6390 T | 63 kW (86 HP)

9310 T | 81 kW (110 HP)
9330 T | 96 kW (130 HP)
9380 T | 132 kW (180 HP)
9380 T | 154 kW (210 HP)

Schäffer Lader

THE SCHÄFFER LOADERS 2028 AND 2030: THE COMPACT ENERGY MACHINES WITH AUTOMOTIVE CONTROL

There are nearly no other loaders which could take on the Schäffer 2028 and 2030 with regard to traction force and agility. The performance of the Kubota Diesel motor is transferred by the hydrostatic drive and the original Schäffer axles into the highest traction force.

Due to the automotive control the speed of the Diesel motor always adapts automatically to the called force. A stalling of the engine is not possible; it always works within the optimal range of speeds. The pulses of the gas pedal are immediately turned; the loaders are always gas-driven. Compared to the previous models, the traction force has been increased once again due to the use of the latest drive components. The Schäffer loaders 2028 and 2030: They can more than you would suppose.



STATE-OF-THE-ART DESIGN

In the design and manufacture of its loaders, Schäffer uses the latest technology.

Three-dimensional CAD enables our engineers to develop new components in a most efficient and reliable manner. New parts and models can be tested on the computer before they are even built. The unrivalled reliability of Schäffer loaders is not least the result of latest technology combined with 50 years of experience in the production of loaders. The loader boom of the 2000 compact class has been designed to allow for maximum lifting power at lowest possible centre of gravity. The conical shape ensures that the driver can at all times see the tool. The beam does not only allow for high lifting heights but also great reach, so that you can move greater loads more safely and easily.

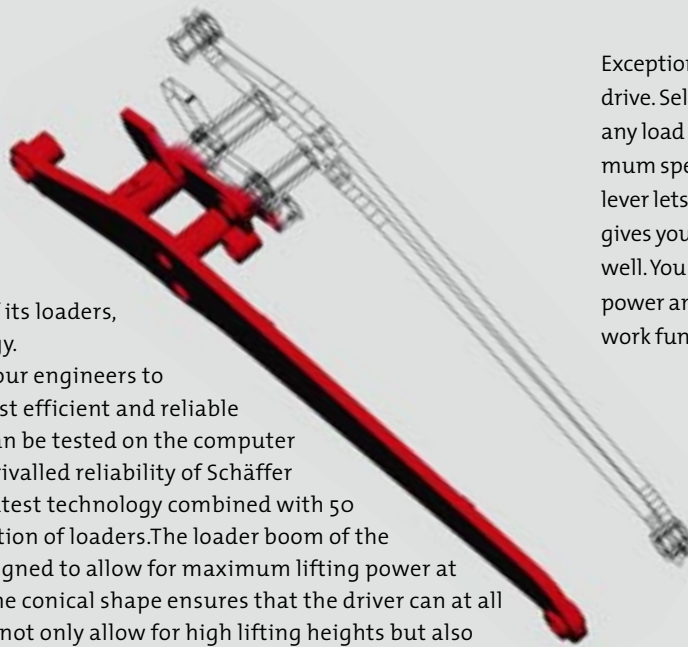

Exceptional comfort is provided by the hydrostatic drive. Select the driving direction, start smoothly with any load and accelerate without shifting to the maximum speed of 15 or 20 km/h. The ergonomic control lever lets you determine the driving direction – and gives you sure control over the hydraulics as well. You can move even heavy loads with power and a fine touch. This makes work fun.



COMPACT LOADERS

SCHÄFFER 2033: THE SMALLEST SCHÄFFER AVAILABLE WITH PROPSHAFT AND MULTIPLE DISK BRAKE

In case the 2030 is a bit too small, the 2033 comes up. This model offers even more pushing power. Due to the higher operating weight, the tipping load is much higher than for a 2030. A special feature is also the maintenance and almost wear-resistant multiple disc brake. This fully enclosed brake system is one of the best on the market and standard for use in much bigger wheel loaders.



POWER THAT KEEPS GOING ALL YEAR ...

You expect technology that delivers both economy and driver comfort, no matter what conditions. With a SCHÄFFER, the hydrostatic drive works brilliantly whatever the demands. The speed can be adjusted automatically to suit various situations without compromising pushing power. The driver always has control, with economy and ergonomics guaranteed. An efficient hydraulic system is the key to an efficient machine and Schäffer's hydraulics can be fine-tuned to do any job with ease. We can even tailor your loader's hydraulics to suit your specific needs in our factory.



For all hydrostatically driven machines, the brake/ inch pedal comes as standard equipment. On request, a continuously variable, electro-proportional speed adjustment is also available.

KUBOTA MOTOR TECHNOLOGY ...

SCHÄFFER has worked in partnership with Kubota, a leading manufacturer of compact diesel motors, for more than 25 years. Kubota has an unsurpassed reputation for quality all over the world. Even in freezing temperatures a Kubota motor will start with ease. You can sense safety and power in the way it sounds, and its excellent torque delivers exceptional performance. Forget maintenance problems – you can expect around 10,000 hours of trouble-free operation. Kubota motors are also exceptionally economical, fuel-efficient and environmentally friendly. A unique prechamber system means a motor can easily be converted to cold-pressed vegetable oil without the need for a separate diesel fuel tank. Kubota motors are future-proof!



ORIGINAL SCHÄFFER AXLES - NO END OF PUSHING POWER ...

Original SCHÄFFER axles are adjusted 100% to each particular loader – that's the secret of their outstanding pushing power, as proved by independent tests. Safety is another important benefit of SCHÄFFER axles. From model 3350, the permitted load bearing capacity is 7t per axle. From model 2033, all loaders are equipped with an oil-immersed, capsuled, multi-disc brake. These are brakes you can always count on! Not only do they deliver optimal deceleration values, they are also totally maintenance-free. Dirt, dust and humidity don't stand a chance.



THE SCHÄFFER 2300 AND 2400 SERIES: CUSTOMIZED LOADERS

The series of 2300/2400 Schäffer is among our best sellers. These powerful and still compact loaders deliver an outstanding performance on construction sites all over the world. Schäffer is able to offer customized loaders, to get your productivity at its best. No matter in which specification the loader will be delivered: The high Schäffer quality is certainly built in. Thus, the strength of the maintenance-free pendulum/articulation joint was increased again. The significant increased tipping loads are coped with easiness. Even in ergonomics the Schäffer loaders are at top of their class. The driver has more space and is pleased with perfectly operable working hydraulics. The powerful four wheel traction drive is fun. The new 4 cylinder motors are running extremely smooth. Independent benchmark tests confirm the high level of Schäffer quality again and again.

THE 2300 AND 2400 SERIES OF SCHÄFFER: ADVANTAGES AT A GLANCE

ROPS-protection roof (choose also front and rear window) or cab.

Adjustable steering column.

Kubota: World market leader of compact diesel motors. Clean, moneysaving, powerful.

Original Schäffer axles: very strong, high pushing power due to best setup of axle, hydrostatic drive and diesel engine, payload of 5 t per axle.

Operators platform with less vibrations.



THE BOOM: SOPHISTICATED AND POWERFUL

Here Schäffers more than 50 years of experience in building loaders pays back. The boom is perfectly integrated in the front frame and ensures problem-free loading works for years. The parallel lift works perfect. High tearing and lifting forces provide fast operations for best efficiency and productivity.



SCHÄFFER "EASY-BRAKE": YOU CAN RELY ON

All Schäffer loaders with propshaft have also the "Easy-Brake", a brake system with multiple disks. They are running in an oil bath which is completely sealed against moisture and dirt. It simply works nearly without wear and maintenance. You can rely on the performance under all circumstances. The fine way of function will convince you as well as the high braking power.



Ball bearing joints for long lifetime expectancy.

One strong lifting cylinder: narrow front chassis, perfect view forward, no tension.

Strong headstocks: A lot of alternatives available. Hydraulic lock as an option.

Versatile due to big range of tools and optional equipment.

Maintenance free articulated pendulum joint with extended warranty.

CLEAR VISIBILITY ...

You can really see what you're doing when you drive a SCHÄFFER. Front visibility is excellent thanks to the narrow, conical loading arm and the low boom pivot. Your vision is also enhanced by the hydraulic cylinders, positioned centrally in the loading arm. As with all hydraulic cylinders these are freely suspended with ball jointed bearings instead of fixed pins or bearing bushes so they will give you trouble-free operation for years.



EVERYTHING SIMPLY WORKS ...

This is what a driver's cockpit should look like. The driver has total control over everything while enjoying excellent visibility. The steering column and seat are fully adjustable to suit the individual operator. Ergonomics is not an end in itself but designed to achieve maximum productivity.



THE 3400 SERIES OF SCHÄFFER: ADVANTAGES AT A GLANCE

ROPS-protection roof (choose also front and rear window) or cab.

Newly constructed engine bonnet offers a better isolation of the sound, perfect view backwards.

Kubota: World market leader of compact diesel motors. Clean, moneysaving, powerful.

Original Schäffer axles: very strong, high pushing power due to best setup of axle, hydrostatic drive and motor, payload of 7 t per axle. 4300 machines with planetary axles and automatic limited slip differentials.



Schäffer Lader

COMFORT AND SAFETY? IT'S YOURS ...

All Schäffer's articulated pendulum joints are totally maintenance-free. Doing away with daily lubrication dramatically reduces your workload. Even more importantly, the joints are virtually indestructible. That's why we offer you a warranty on this component of 3 years or 3000 operating hours. SCHÄFFER loaders are so tough they just keep going, yet they are also extremely agile and manoeuvrable.



ROBUST, POWERFUL TECHNOLOGY

Do you need to transfer bulk goods and transport heavy loads? The SCHÄFFER 5300 series wheel loaders are made for this. The Z-kinematic has a powerful grabbing action, and the ability to lift and tip over loads with ease. At the same time, the freely suspended rear axle greatly increases the machine's durability and stability.



Schäffer Lader



COMPUTER OPTIMIZED LOADING ARM WITH Z-KINEMATICS - SIMPLY STRONG

Do you want maximum break-out and lifting forces? SCHÄFFER delivers. Our expert engineers use the latest in three-dimensional computer-aided design, optimised by years of experience. The result is superior visibility to the front: tapering from narrower at the mount to wider at the tool. Even for demanding tasks, a SCHÄFFER is everything you could ask for and more. Half a century of expertise pays off!

COMPACT LOADERS



The 4350Z, with an operating weight of just over 3,5t, is a great mid-range machine. It's easy to load even the biggest trailers thanks to a lifting height of 3.26 m. The hardtop can be equipped with a front and rear window as an alternative to the comfort cabin. Powerful Kubota motors with 37 kW (50 HP) or 44 kW (60 HP) drive the machine. The steady under load, switchable high speed gear (20 km/h) is standard.



SCHÄFFER 9300 Z/9330 Z: WITH 3.80 M LIFTING HEIGHT AT TOP OF IT'S CLASS

Nothing can replace lifting height – but lifting height. The 3.80 m of the SCHÄFFER 9300 Z/9330 Z are absolutely unchallenged. With high lift the loader becomes even more versatile. Ton on ton easy loading, reliably over years. Only a wheel loader made by SCHÄFFER creates this.

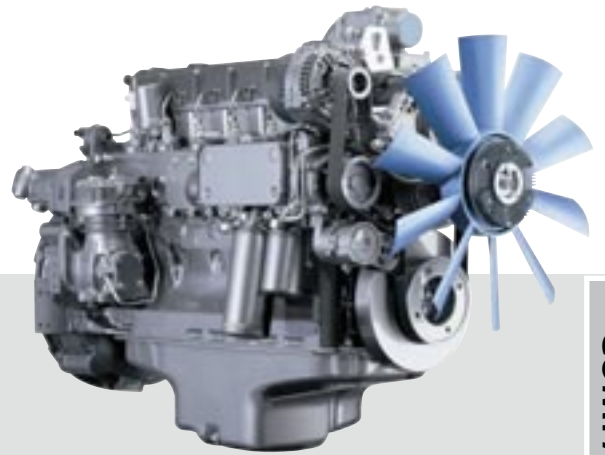

Water cooled engines of Deutz. Indestructible, thrifty, quiet and strong. Together with SCHÄFFER 9300 series a winning team.

COMPACT LOADERS



The rear axle is oscillating for better stability.

TECHNICAL DATA

	2028 / 2030		2033	2336	2345
Engine	3 cyl. Kubota 19 kW (26 HP)	3 cyl. Kubota 22 kW (30 HP)	3 cyl. Kubota 24 kW (33 HP)	4 cyl. Kubota 26 kW (36 HP)	4 cyl. Kubota Turbo 33 kW (45 HP)
Driving hydraulics	Hydrostatic automotive		Hydrostatic automotive	Hydrostatic automotive	Hydrostatic automotive
Tyres	7.00 - 12 AS Option I 27x8.50-15 Option II 27x10.50-15 Option III 26x12.00-12		10.075 - 15.3 AS Option I 27x10.5-15 Option II 31x15.5-15	10.075 - 15.3 AS Option I 27x10.5 - 15 Option II 31x15.5 - 15	10.075 - 15.3 AS Option I 27x10.5 - 15 Option II 31x15.5 - 15
Service brake	Hydrostatic/mechanical		Combination Hydrostatic and multiple-disk	Combination Hydrostatic and multiple-disk	Combination Hydrostatic and multiple-disk
Parking brake	Mechanical drum brake		Multiple Disk in oil Bath	Multiple Disk in oil Bath	Multiple Disk in oil Bath
Working hydraulics	Flow rate: 33 l/min Working pressure: 200 bar		Flow rate: 42 l/min Working pressure: 200 bar	Flow rate: 42 l/min Working pressure: 200 bar	Flow rate: 42 l/min Working pressure: 200 bar
Steering	Hydraulic Articulated Pendulum Steering		Hydraulic Articulated Pendulum Steering	Hydraulic Articulated Pendulum Steering	Hydraulic Articulated Pendulum Steering
Lifting capacity	1,500 kg		1,600 kg	1,700 kg	1,700 kg
Tip-over load (straight)	920 kg		1,000 kg	1,200 kg	1,300 kg
Tip-over load (articulated)	550 kg		720 kg	900 kg	930 kg
Axles	Original Schäffer axles 4 wheel nut rim		Original Schäffer axles 5 wheel nut rim, Option: automatic limited-slip differential	Original Schäffer axles 6 wheel nut rim, Option: automatic limited-slip differential	Original Schäffer axles 6 wheel nut rim, Option: automatic limited-slip differential
Operating weight	1,750 kg		1,880 kg/2,080 kg with cab	2,200 kg/2,400 kg with cab	2,200 kg/2,400 kg with cab
Speed	0 - 15 km/h		0 - 15 km/h	0 - 20 km/h 2 speeds gear switching under load possible	0 - 20 km/h 2 speeds gear switching under load possible
Electrical system	Operating voltage 12 V		Operating voltage 12 V	Operating voltage 12 V	Operating voltage 12 V
Fluid capacities	Fuel: 23 l Hydraulic oil: 30 l		Fuel: 40 l Hydraulic oil: 30 l	Fuel: 40 l Hydraulic oil: 30 l	Fuel: 40 l Hydraulic oil: 30 l

	2436 / 2445		3350 / 3360	3450 / 3460
Engine	4 cyl. Kubota 4 cyl. Kubota Turbo 26 kW (36 HP) 33 kW (45 HP)		4 cyl. Kubota 4 cyl. Kubota Turbo 37 kW (50 HP) 44 kW (60 HP)	4 cyl. Kubota 4 cyl. Kubota Turbo 37 kW (50 HP) 44 kW (60 HP)
Driving hydraulics	Hydrostatic automotive		Hydrostatic automotive	Hydrostatic automotive
Tyres	10.075 - 15.3 AS Option I 27x10.5 - 15 Option II 31x15.5 - 15		10.075 - 15.3 AS Option I 11.5/80 - 15.3 AS Option II 31x15.5 - 15 Option III 15.0/55 - 17 Option IV 425/55 R17	11.5/80 - 15.3 AS Option I 31x15.5 - 15 Option II 15.0/55 - 17 Option III 425/55 R17
Service brake	Combination Hydrostatic and multiple-disk		Combination Hydrostatic and multiple-disk	Combination Hydrostatic and multiple-disk
Parking brake	Multiple Disk in oil Bath		Multiple Disk in oil Bath	Multiple Disk in oil Bath
Working hydraulics	Flow rate: 42 l/min Working pressure: 200 bar		Flow rate: 48 l/min Working pressure: 200 bar	Flow rate: 48 l/min Working pressure: 200 bar
Steering	Hydraulic Articulated Pendulum Steering		Hydraulic Articulated Pendulum Steering	Hydraulic Articulated Pendulum Steering
Lifting capacity	1,900 kg		2,000 kg	2,100 kg
Tip-over load (straight)	1,600 kg		1,800 kg	1,950 kg
Tip-over load (articulated)	1,200 kg		1,400 kg	1,600 kg
Axles	Original Schäffer axles 6 wheel nut rim, Option: automatic limited-slip differential		Original Schäffer axles 6 wheel nut rim, Option: automatic limited-slip differential	Original Schäffer axles 6 wheel nut rim, Option: automatic limited-slip differential
Operating weight	2,200 kg/2,400 kg with cab		2,700 kg/2,900 kg with cab	2,700 kg/2,900 kg with cab
Speed	0 - 20 km/h 2 speeds gear switching under load possible		0 - 20 km/h 2 speeds gear switching under load possible	0 - 20 km/h 2 speeds gear switching under load possible Option: 0 - 30 km/h
Electrical system	Operating voltage 12 V		Operating voltage 12 V	Operating voltage 12 V
Fluid capacities	Fuel: 40 l Hydraulic oil: 30 l		Fuel: 55 l Hydraulic oil: 50 l	Fuel: 55 l Hydraulic oil: 50 l

DIMENSIONS

Schäffer Lader

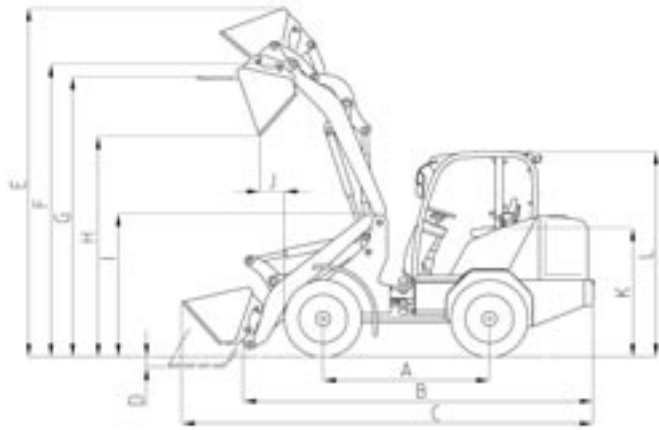
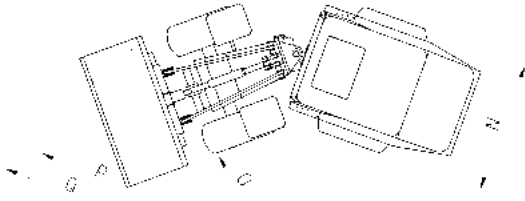

		2028 2030	2033	2336	2345	2436	2445	3350 3360	3450 3460
A	Axle base [mm]	1.375	1.410	1.550	1.550	1.755	1.755	1.730	1.850
B	Chassis length [mm]	2.780	2.930	3.085	3.085	3.320	3.320	3.485	3.680
C	Total length with standard bucket [mm]	3.530	3.610	3.880	3.880	3.960	3.960	4.185	4.400
D	Excavating depth [mm]	110	110	90	90	105	105	90	90
E	Max. working height [mm]	3.460/3.720*	3.540/3.770*	3.570/3.800*	3.570/3.800*	3.230	3.230	3.550/3.800*	3.250
F	Max. bucket pivot point [mm]	2.800/3.060*	2.880/3.110*	2.880/3.110*	2.880/3.110*	2.500	2.500	2.950/3.200*	2.600
G	Max. loading height with pallet fork [mm]	2.560/2.920*	2.640/2.970*	2.680/3.100*	2.680/3.100*	2.360	2.360	2.810/2.940*	2.500
H	Max. load over height [mm]	1.965/2.265*	2.045/2.300*	2.045/2.300*	2.045/2.300*	1.700	1.700	2.140/2.390*	1.800
I	Max. dump height [mm]	1.600/1.725*	1.680/1.780*	1.690/1.790*	1.690/1.790*	1.490	1.490	1.700/1.790*	1.550
J	Dump range [mm]	440	440	470	470	260	260	560	510
K	Seat height [mm]	1.055	1.160	1.160	1.160	1.160	1.160	1.150	1.150
L	Height with protective roof [mm] Height with cabin/hardtop [mm]	2.090 -	2.220 2.150	2.215 2.110	2.215 2.110	2.215 2.110	2.215 2.110	2.240 2.200	2.240 2.200
N	Total width [mm]	890 – 1.240	1.020 – 1.290	1.020-1.390	1.020-1.390	1.020-1.390	1.020-1.390	1.020-1.540	1.230 – 1.600
O	Track arc inside [mm]	660	580	800	800	1.000	1.000	1.100	1.100
P	Track arc outside [mm]	1.560	1.600	1.820	1.820	2.070	2.070	2.120	2.120
Q	External radius with standard bucket [mm]	1.950	1.950	2.250	2.250	2.450	2.450	2.500	2.500

* with high lift

COMPACT LOADERS



TECHNICAL DATA

	4350 Z/4360 Z	5058 Z/ZS	5370 Z/5390 Z	9300 Z	9330 Z
Engine	4 cyl. Kubota 37 kW (50 HP) 4 cyl. Kubota Turbo 44 kW (60 HP)	4 cyl. Kubota Turbo 44 kW (60 HP) 4 cyl. Kubota 51 kW (70 HP)	4 cyl. Kubota 51 kW (70 HP) 4 cyl. Kubota Turbo 63 kW (86 HP)	4 cyl. Deutz Turbo Intercooler 81 kW (110 HP)	4 cyl. Deutz Turbo Intercooler 96 kW (130 HP)
Driving hydraulics	Hydrostatic automotive	Hydrostatic automotive	Hydrostatic automotive	Hydrostatic automotive	Hydrostatic automotive
Tyres	11.5/80 - 15.3 AS Option I 15.0/55 - 17 AS Option II 425/55 R17	15.0/55 - 17 AS Option I 425/55 R17 Option II 500/45-20	15.0/55-17 AS Option I 500/45-20 AS Option II 425/55 R17	405/70-20 Option I 365/70-R18 Option II 550/45-22.5	600/40-22.5
Service brake	Combination Hydrostatic and multiple-disk	Combination Hydrostatic and multiple-disk	Combination Hydrostatic and multiple-disk	Combination Hydrostatic and multiple-disk	Combination Hydrostatic and multiple-disk
Parking brake	Multiple Disk in Oil Bath	Multiple Disk in Oil Bath	Multiple Disk in Oil Bath	Multiple Disk in Oil Bath	Multiple Disk in Oil Bath
Working hydraulics	Flow Rate: 70 l/min Working Pressure: 200 bar	Flow Rate: 70 l/min Working Pressure: 200 bar	Flow Rate: 70 l/min Working Pressure: 200 bar	Flow Rate: 80 l/min Working Pressure: 200 bar	Flow Rate: 80 l/min Working Pressure: 200 bar
Steering	Hydraulic Articulated Pendulum Steering	Fully Hydraulic Articulated Steering	Fully Hydraulic Articulated Steering	Fully Hydraulic Articulated Steering	Fully Hydraulic Articulated Steering
Lifting capacity	2.400 kg	2.800 kg	2.800 kg/2.800 kg	4.200 kg	4.200 kg
Tip-over load (straight)	2.200 kg	2.400 kg	2.600 kg/2.750 kg	3.800 kg	4.000 kg
Tip-over load (articulated)	1.700 kg	2.100 kg	2.250 kg/2.400 kg	3.200 kg	3.400 kg
Axles	Original SCHÄFFER axles, 6 wheel nut rim; planetary axle and automatic limited slip brake	Original SCHÄFFER axles, 6 wheel nut rim; planetary axle and automatic limited slip brake, Oscilating rear axle	Original SCHÄFFER axles, 6 wheel nut rim; planetary axle and automatic limited slip brake, Oscilating rear axle	ZF-Axles, 8 wheel nut rim; planetary axle and automatic limited slip brake, Oscilating rear axle	ZF-Axles, 8 wheel nut rim; planetary axle and automatic limited slip brake, Oscilating rear axle
Operating Weight	protective roof: 3.400 kg cab: 3.520 kg	canopy: 3.920 kg cab: 4.070 kg	canopy: 4.150/4.520 kg cab: 4.300/4.670 kg	cab: 5.550 kg/5.950 kg*	cab: 6.300 kg
Speed	0 – 20 km/h, 2 speeds gear switching under load possible, Option: 0 – 30 km/h	0 – 20 km/h, 2 speeds gear switching under load possible,	0 – 20 km/h, 2 speeds gear switching under load possible, Option: 0 – 30 km/h	0 – 20 km/h, 2 speeds gear switching under load possible, Option: 0 – 35 km/h	0 – 20 km/h, 2 speeds gear switching under load possible, Option: 0 – 35 km/h
Electrical system	Operating Voltage 12 V	Operating Voltage 12 V	Operating Voltage 12 V	Operating Voltage 12 V	Operating Voltage 12 V
Fluid capacities	Fuel: 90 l Hydraulic oil: 60 l	Fuel: 65 l Hydraulic oil: 60 l	Fuel: 65 l Hydraulic oil: 60 l	Fuel: 95 l Hydraulic oil: 105 l	Fuel: 95 l Hydraulic oil: 105 l

* High lift



Schäffer Lader

DIMENSIONS

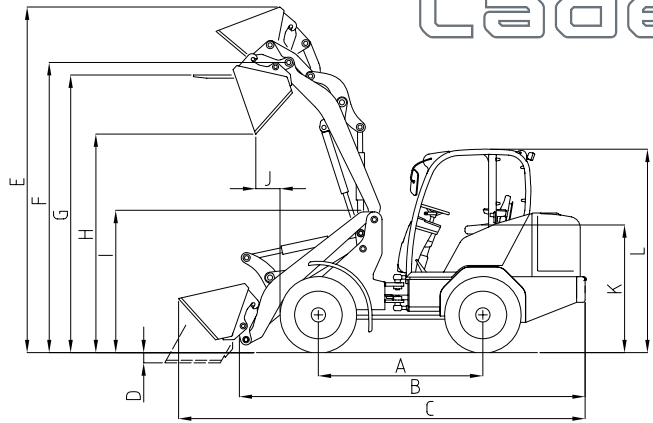
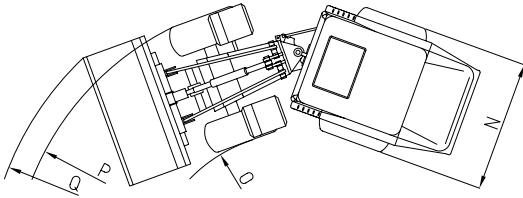

		4350 Z/4360 Z	5058 Z/ZS	5370 Z/5390 Z	9300 Z	9330 Z
A	Axle base [mm]	2.000	1.930	1.930	2.300	2.300
B	Chassis length [mm]	4.050	4.240	4.480	4.850	4.850
C	Total length with standard bucket [mm]	4.730	4.870	5.250	5.560	5.560
D	Excavating depth [mm]	120	180	180	160	160
E	Max. working height [mm]	4.060	4.070	4.070	4.035/4.435*	4.035/4.435*
F	Max. bucket pivot point [mm]	3.260	3.400	3.400	3.400/3.800*	3.400/3.800*
G	Max. loading height with pallet fork [mm]	3.050	3.175	3.175	3.175/3.575*	3.175/3.575*
H	Max. load over height [mm]	2.500	2.700	2.700	2.700/3.100*	2.700/3.100*
I	Max. dump height [mm]	1.570	1.640	1.640	1.625/1.825*	1.625/1.825*
J	Dump range [mm]	640	600	600	465	465
K	Seat height [mm]	1.270	1.340	1.340	1.510	1.510
L	Height with protective roof [mm] Height with cabin/hardtop [mm]	2.270 2.220	- 2.320	- 2.320	- 2.500	- 2.500
N	Total width [mm]	1.230 – 1.600	1.420 – 1.800	1.420 – 1.800	1.800 – 2.080	2.110
O	Track arc inside [mm]	1.450	1.670	1.560	1.890	1.760
P	Track arc outside [mm]	2.680	3.090	3.130	4.000	4.130
Q	External radius with standard bucket [mm]	3.010	3.750	3.750	4.450	4.450

* High lift

COMPACT LOADERS



PIVOT STEER TELELOADERS 6370 T/6390 T: COMPACT MACHINES WITH EXCELLENT ALL ROUND VIEW

The new articulated teleloaders with an operating weight of 5 t covers at Schäffer the middle segment in teleloaders range. Unique selling points of these models are agility, suitability also for use in hard to reach areas, the new SCV cab and compact machine measurements. Just in case bigger Schäffer loaders of the 9300s series are out of question due to their dimensions, the 6300s come up to with their advantages. These machines are dedicated for use in narrow conditions, e.g. for use "under roof".

New SCV-Cab: ROPS and FOPS approved; very spacious, best ergonomics and all round view.

Kubota: World market leader of compact diesel motors. Clean, moneysaving, powerful.

Original SCHÄFFER planetary axles: very strong, high pushing power due to best setup of axle, hydrostatic drive and motor; payload of 7 t per axle; with automatic limited slip brakes. Oscillating rear axle for best stability.

Extremely strong articulation joint.



Schäffer Lader



The articulation joint is really heavy duty.
You will hardly find a stronger one.

THE 6300 SERIES OF SCHÄFFER: ADVANTAGES AT A GLANCE

Low boom pivot for perfect view.

Sliding elements free of wear.

Tilt cylinder well protected
in telescopic boom.

Very strong carriage, fast and safe
hydraulic coupling of tools.

CAD optimized lifting arm, best lifting height
and reach, perfect parallel lift.

Versatile due to big range of tools
and optional equipment.



TELELOADER 9310 T / 9330 T FROM SCHÄFFER: THE LOADER WITH ADDED VALUE

Here are only five features that make these loaders added-value machines:

1. The driver has an excellent all-round view due to the low boom pivot and a new designed SCV cab. The driver can always see clearly in all directions.
2. The lifting height of 5.10 meters is unique in the 6-ton class. With SCHÄFFER you can reach higher and farther.
3. The oscillating rear axle contributes to the excellent stability of the loader. Good for your safety and for use on rough terrain.
4. The tilt cylinder is protected within the telescoping arm, which also protects your pocketbook on the long run.
5. The sliding elements in the telescoping arm were made of Ferroform, a special material without any wear.

The 9310 T/9330 T are our most popular pivot steer teleloaders. And for more than just five reasons.

Schäffer Lader



The new watercooled TCD 2012 4-cylinder engines from Deutz. You can be sure that the engines are extremely reliably even under difficult conditions. The technical data is convincing: one litre displacement per cylinder, excellent torque increase, specific fuel consumption of approximately 200 g/kWh, quiet and clean.

TELELOADERS



Oscillating axle for more stability and higher excavating force.

TECHNICAL DATA

	460 T /470 T	6370 T	6390 T	9310 T	9330 T	9380 T
Engine	4 cyl. Kubota Turbo 44 kW (60 HP) 4 Cyl. Kubota 51 kW (70 HP)	4 cyl. Kubota 51 kW (70 HP)	4 cyl. Kubota Turbo 63 kW (86 HP)	4 cyl. Deutz Turbo Intercooler 81 kW (110 HP)	4 cyl. Deutz Turbo Intercooler 96 kW (130 HP)	4 cyl. Deutz Turbo Intercooler 132 kW (180 HP) 154 kW (210 HP)
Driving hydraulics	Hydrostatic- automotive	Hydrostatic- automotive	Hydrostatic- automotive	Hydrostatic- automotive	Hydrostatic- automotive	Hydrostatic- automotive
Tyres	15.0/55 - 17 AS Option I 425/55 R17	15.0/55 - 17 AS Option I 425/55 R17 Option II 500/45-20	425/55 R17 Option I 500/45-20 Option II 15.5/55R18	405/70-20 Option I 365/70-R18 Option II 550/45-22.5	600/40-22.5	650/55R26.5
Service brake	Combination Hydrostatic and multiple-disk	Combination Hydrostatic and multiple-disk	Combination Hydrostatic and multiple-disk	Combination Hydrostatic and multiple-disk	Combination Hydrostatic and multiple-disk	Combination Hydrostatic and multiple-disk
Parking brake	Multiple Disk in Oil Bath	Multiple Disk in Oil Bath	Multiple Disk in Oil Bath	Multiple Disk in Oil Bath	Multiple Disk in Oil Bath	Multiple Disk in Oil Bath
Working hydraulics	Flow Rate: 70 l/min Working Pressure: 220 bar	Flow Rate: 70 l/min Working Pressure: 220 bar	Flow Rate: 70 l/min Working Pressure: 220 bar	Flow Rate: 80 l/min Working Pressure: 220 bar	Flow Rate: 85 l/min Working Pressure: 220 bar	Flow Rate: 190 l/min Working Pressure: 220 bar
Steering	Hydraulic Articulated Steering	Hydraulic Articulated Steering	Hydraulic Articulated Steering	Hydraulic Articulated Steering	Hydraulic Articulated Steering	Hydraulic Articulated Steering
Lifting capacity	1.950 kg	2.800 kg	2.800 kg	3.800 kg	4.200 kg	4.900 kg
Tip-over load, straight	1.800 kg*/1.900 kg*	2.400 kg*	2.500 kg*	3.000 kg*	3.400 kg*	4.400 kg*
Axles	Original SCHÄFFER axles, 6 wheel nut rim; planetary axle and automatic limited slip brake, Oscilating rear axle	Original SCHÄFFER axles, 6 wheel nut rim; planetary axle and automatic limited slip brake, Oscilating rear axle	Original SCHÄFFER axles, 6 wheel nut rim; planetary axle and automatic limited slip brake, Oscilating rear axle	ZF-Axles, 8 wheel nut rim; planetary axle and automatic limited slip brake, Oscilating rear axle	ZF-Axles, 8 wheel nut rim; planetary axle and automatic limited slip brake, Oscilating rear axle	Dana-Axles, 10 wheel nut rim; planetary axle and automatic limited slip brake, Oscilating rear axle
Operating Weight	canopy: 3.950 kg cab: 4.150 kg	canopy: 4.670 kg cab: 4.820 kg	canopy: 4.750 kg cab: 4.900 kg	cab: 6.000 kg	cab: 6.600 kg	cab: 14.000 kg
Speed	0 – 20 km/h, 2 speeds gear switching under load possible Option: 0 – 30 km/h	0 – 20 km/h, 2 speeds gear switching under load possible Option: 0 – 30 km/h	0 – 20 km/h, 2 speeds gear switching under load possible Option: 0 – 30 km/h	0 – 20 km/h, 2 speeds gear switching under load possible Option: 0 – 35 km/h	0 – 20 km/h, 2 speeds gear switching under load possible Option: 0 – 35 km/h	0 – 40 km/h, 3 speeds ranges
Electrical system	Operating Voltage 12 V	Operating Voltage 12 V	Operating Voltage 12 V	Operating Voltage 12 V	Operating Voltage 12 V	Operating Voltage 12 V
Fluid capacities	Fuel: 60 l Hydraulic oil: 60 l	Fuel: 65 l Hydraulic oil: 60 l	Fuel: 75 l Hydraulic oil: 70 l	Fuel: 95 l Hydraulic oil: 85 l	Fuel: 105 l Hydraulic oil: 95 l	Fuel: 200 l Hydraulic oil: 155 l

*see diagramm

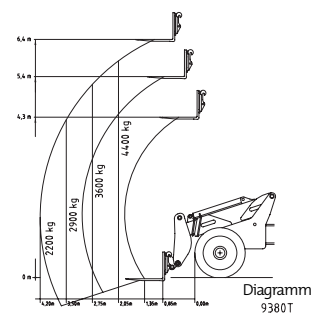
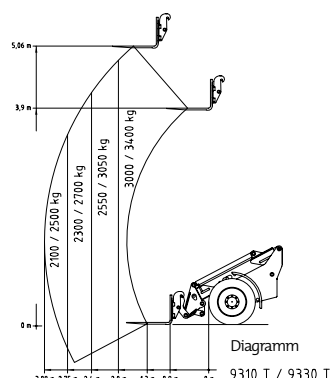
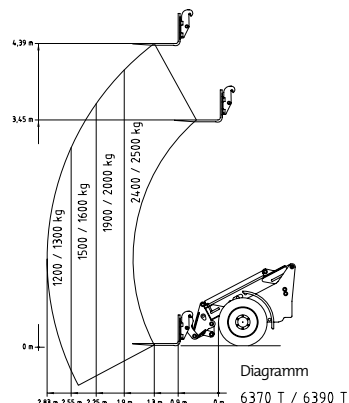
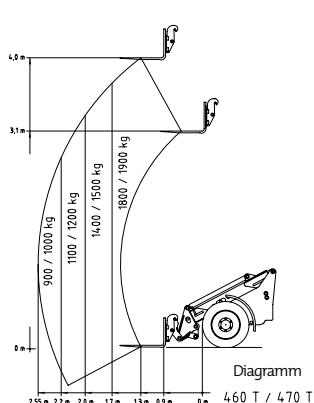

DIMENSIONS

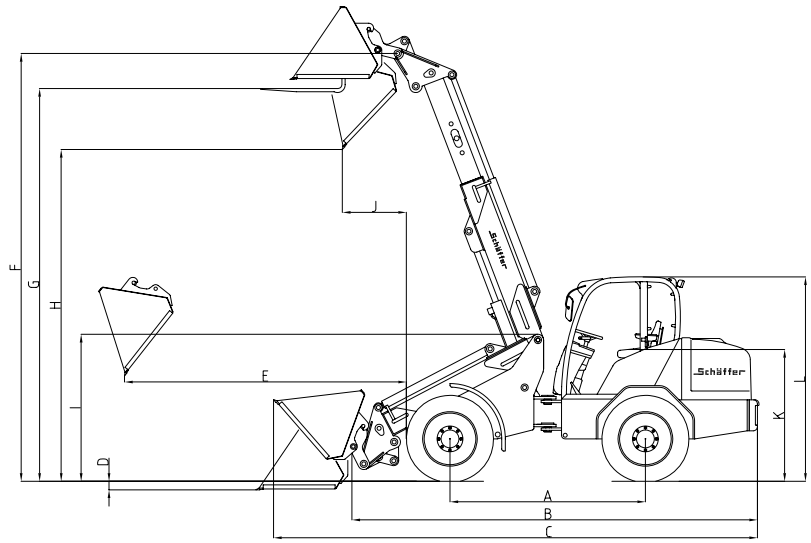
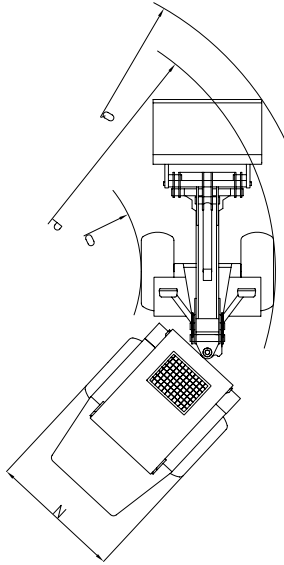

		460 T/470 T	6370 T	6390 T	9310 T	9330 T	9380 T
A	Axle base [mm]	1.720	2.240	2.240	2.480	2.480	2.935
B	Chassis length [mm]	4.190	4.950	4.950	5.250	5.250	6.900
C	Total length with standard bucket [mm]	4.990	5.580	5.580	6.040	6.040	7.380
D	Excavating depth [mm]	180	150	150	190	190	140
E	Max. working height [mm]	1.640	2.300	2.300	2.900	2.900	3.850
F	Max. bucket pivot point [mm]	4.250	4.660/5.100*	4.660/5.100*	5.100	5.100	6.900
G	Max. loading height with pallet fork [mm]	4.020	4.390	4.390	5.060	5.060	6.420
H	Max. load over height [mm]	3.340	3.530	3.530	4.190	4.190	5.350
I	Max. dump height [mm]	1.580	1.660	1.660	1.780	1.780	2.287
J	Dump range [mm]	1.160	970	970	730	730	1.170
K	Seat height [mm]	1.290	1.340	1.340	1.510	1.510	2.040
L	Cab/Hardtop height [mm]	2.210	2.320	2.320	2.500	2.500	2.850
N	Total width [mm]	1.370 - 1.600	1.570 - 1.800	1.570 - 1.800	1.800 - 2.080	2.110	2.400
O	Track arc inside [mm]	1.410	1.750	1.750	2.240	1.990	2.570
P	Track arc outside [mm]	3.310	3.925	3.925	4.350	4.100	5.000
Q	External radius with standard bucket [mm]	3.820	4.530	4.530	3.650	3.650	5.500

* Option: High lift



SCHÄFFER LOADER WITH NEW CAB "SCV"

The new SCHÄFFER SCV-cab (**S**ilence/**C**omfort/**V**iew) with which the wheel loader 5300 Z and 9300 Z and the 6300 and 9300 series teleloaders are equipped, offers more comfort for long working days. Already from the outside the new cabin shows dynamism and power. You can really enjoy climbing due to the safe steps and the largely dimensioned doors. The interior design in friendly colors conforms to the demand for high quality standards which is typical for SCHÄFFER. The seat in its standard version already offers real comfort and setting options. If desired an air spring seat is also available. The steering-wheel is adjustable in height and inclination. All operating elements and displays are arranged clearly and logically. All work hydraulics can be dosed absolutely delicately by means of a joystick. This is supported by the use of precontrolled valves. Arm-rest and joystick form a unit with the seat and accept all movements of the seat. Pure ergonomics! All drivers will like the rear window of the SCV-cab which can be opened to have a better circulation of air.



The powerful three-stage fan ensures always perfect view. 7 air nozzles!

AS STANDARD ON SCV CAB



Perfect view upwards.
With roller blind



Box with cover
(9300 series only)



Battery switch



Power plug



Bottle holder



2 x Dual Power working lamp front,
1 x Single Power rear



Arm-rest and joystick form a unit with the seat and accept all movements of the seat. Pure ergonomics!



The way SCHÄFFER loaders are developed, built and serviced is unique. The difference is our 50 years of experience. First, we think about the operator; we want to make his work safer, more comfortable – and more profitable. To this end, we are equipped with the most modern development and production technologies at our plant in Erwitte, Germany. Ultimately, it is our associates who work with our customers to continuously develop new solutions. Long years of commitment to the company combined with an enduring spirit of innovation are the basis of our exceptional worldwide success.

The name SCHÄFFER Loaders stands for more than one-of-a-kind product quality. It also stands for safety and optimal service, which we guarantee not only in Germany but around the globe.

The purchase of a SCHÄFFER loader is the beginning of a long-term relationship. Only original replacement parts allow your machine to remain a 100% true SCHÄFFER over the years. Only then will it guarantee the reliability you rightly expect. We offer you and our service partners a 24 hour delivery service – 7 days a week, 365 days a year.



made by SCHÄFFER

SCHÄFFER offers you a product line-up of over 40 different models, each of which can be adapted to your individual requirements. Our loaders can be used in many different industries: in agriculture or construction, in horticulture or landscaping, in industry and trade, in horse husbandry or warehousing. Whatever the industry, SCHÄFFER is always your first choice.



Schaeffer Lader

Your Dealer:

SCHÄFFER MASCHINENFABRIK GMBH

Postfach 10 67 | D-59591 Erwitte

Phone +49 02943 9709-0

Fax +49 02943 9709-50

info@schaeffler-lader.de

www.schaeffler-lader.de